

Instruction Manual

30-2854



Introduction

The model 30-2854 CDI Pencil Coils are optimized for use with high energy CDI systems. The kit includes all the necessary terminals and connectors to install your coils. Make sure to apply a liberal amount of dielectric grease to the connector terminals and the tip of the body of the spark plugs. Failure to do this may cause arcs to the cylinder head and cause a misfire.

Kit Contents

The 30-2854 kits contain:

- 1 CDI coil
- 1 Mating connector
- 1 mating connector lock
- 2 wire seals
- 2 terminals
- 1 Dielectric grease

The 30-2854-4PK kits contain:

- 4 CDI coil
- 4 Mating connectors
- 4 mating connector locks
- 8 wire seals
- 8 terminals
- 2 Dielectric grease

Dimensions

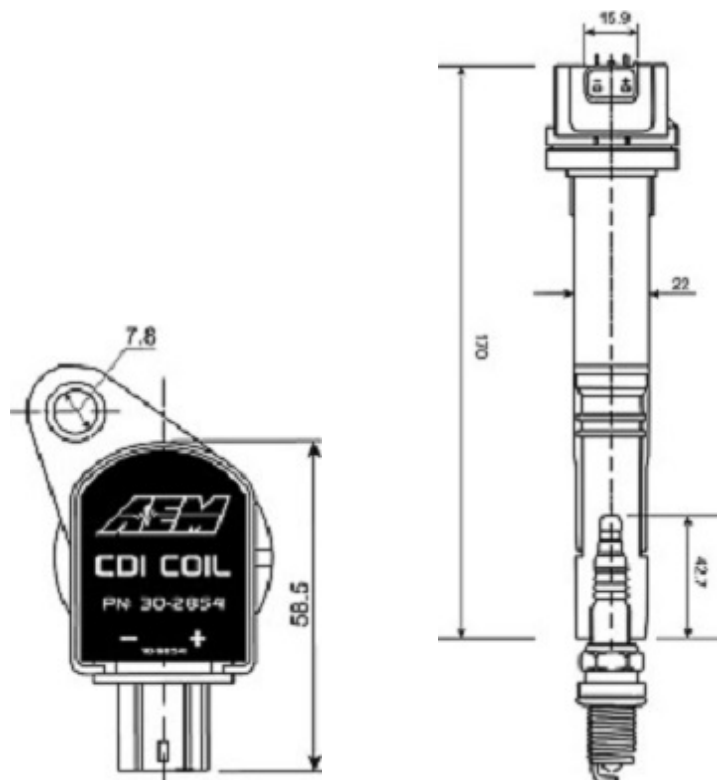

12 Month Limited Warranty

Advanced Engine Management Inc. warrants to the consumer that all AEM High Performance products will be free from defects in material and workmanship for a period of twelve (12) months from date of the original purchase. Products that fail within this 12-month warranty period will be repaired or replaced at AEM's option, when determined by AEM that the product failed due to defects in material or workmanship. This warranty is limited to the repair or replacement of the AEM part. In no event shall this warranty exceed the original purchase price of the AEM part nor shall AEM be responsible for special, incidental or consequential damages or cost incurred due to the failure of this product. Warranty claims to AEM must be transportation prepaid and accompanied with dated proof of purchase. This warranty applies only to the original purchaser of product and is non-transferable. All implied warranties shall be limited in duration to the said 12-month warranty period. Improper use or installation, accident, abuse, unauthorized repairs or alterations voids this warranty. AEM disclaims any liability for consequential damages due to breach of any written or implied warranty on all products manufactured by AEM. Warranty returns will only be accepted by AEM when accompanied by a valid Return Merchandise Authorization (RMA) number. Product must be received by AEM within 30 days of the date the RMA is issued.

UEGO oxygen sensors are considered wear items and are not covered under warranty.

Please note that before AEM can issue an RMA for any electronic product, it is first necessary for the installer or end user to contact the EMS tech line at 1-800-423-0046 to discuss the problem. Most issues can be resolved over the phone. Under no circumstances should a system be returned or a RMA requested before the above process transpires.

AEM will not be responsible for electronic products that are installed incorrectly, installed in a non-approved application, misused, or tampered with.

Any AEM electronics product can be returned for repair if it is out of the warranty period. There is a minimum charge of \$50.00 for inspection and diagnosis of AEM electronic parts. Parts used in the repair of AEM electronic components will be extra. AEM will provide an estimate of repairs and receive written or electronic authorization before repairs are made to the product.