

GT2860RS

The "Disco Potato"

Garrett®
by Honeywell

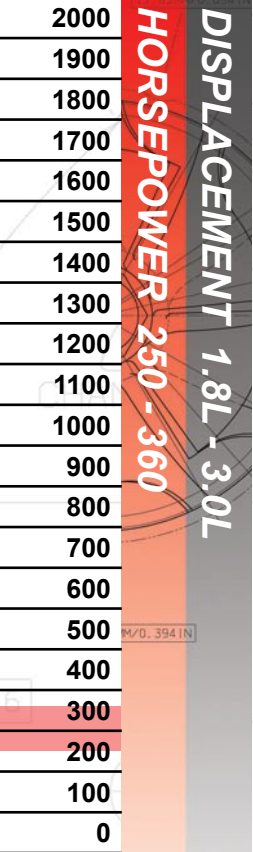

- Dual ball bearing, oil & water-cooled CHRA
- Internally wastegated turbine housing complete with actuator
- Upgrade turbocharger for GT2554R (471171-3) and GT2560R (466541-1); turbine housing flanges are outline interchangeable
- Turbine wheel is cast from "Inconel" material for extreme applications
- "Disco Potato" refers to the Nissan Sentra (potato-shaped body) with psychedelic color-change paint (disco) that was fitted with one of the first GT2860RS' in a project car build. The name stuck.

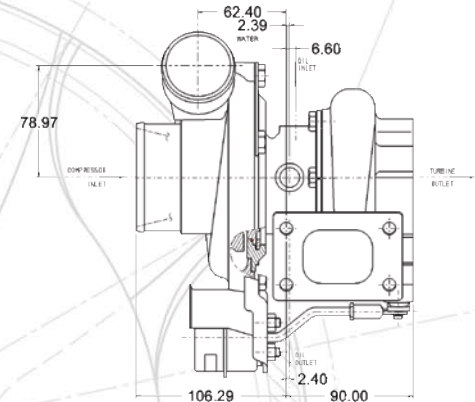

GT2860RS		COMPRESSOR				TURBINE		
Turbo PN	CHRA PN	Ind Whl Dia	Exd Whl Dia	Trim	A/R	Whl Dia	Trim	A/R
739548-1	446179-66	47.2mm	60.1mm	62	0.60	53.9mm	76	0.86
739548-5	446179-66	47.2mm	60.1mm	62	0.60	53.9mm	76	0.64

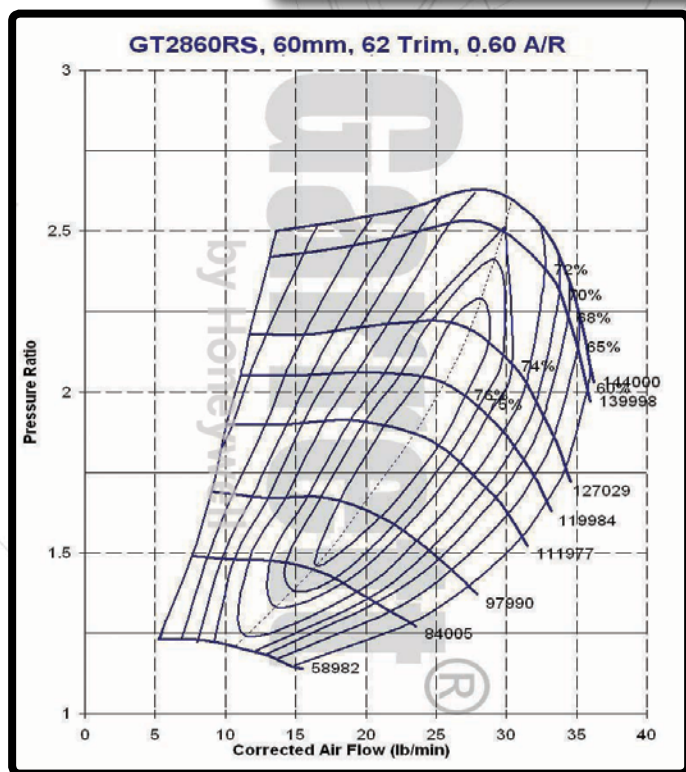

TURBINE HOUSING OPTIONS	
PN	A/R
430609-230	0.64
430609-231	0.86

