

EFR 9180-D

600 - 1000 HP Turbo

EFR SERIES



Key Turbo Features

- Gamma-Ti turbine wheel
- Standard T4 mounting flange

Not Included with Turbo Assemblies:

- Speed sensor
- Turbine outlet V-Band
- Turbine inlet gasket
- Oil drain gasket or drain port fitting

COMPRESSOR MAP

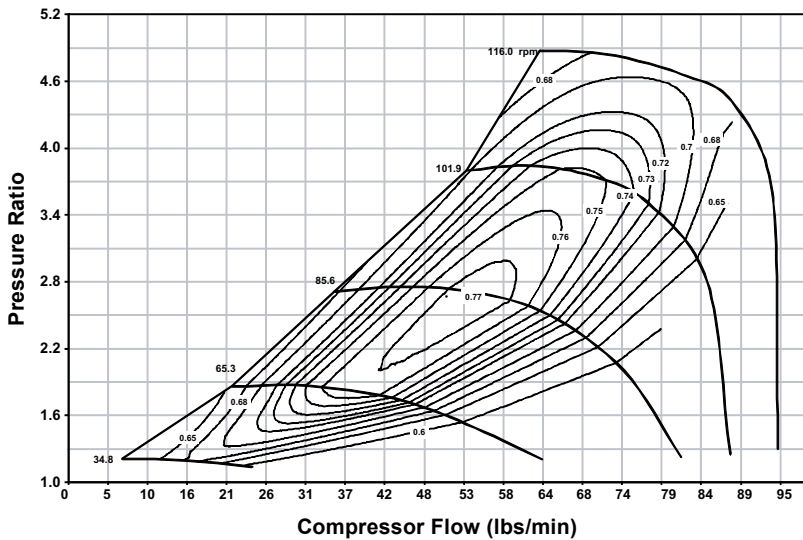

TURBINE HOUSING OPTIONS

Turbine Housing Part Number	A/R	Inlet Flange Shape	Housing Config.
12801008002	0.83	T3	Single Scroll WG
12801019009	0.92	T4	Twin Scroll WG
12801019001	1.05	T4	Twin Scroll Non-WG
12801008006	1.45	T4	Twin Scroll Non-WG

Turbo Part #	Turbo Frame Size	Super Core Part #	Comp. Wheel Outer Dia. (mm)	Comp. Wheel Inducer Dia.	Turbine Wheel Outer Dia.	Turbo A/R	Inlet Flange Config.
179394	B2	179356	91	68	80	1.05	T4

TURBO FRAME DIMENSIONS

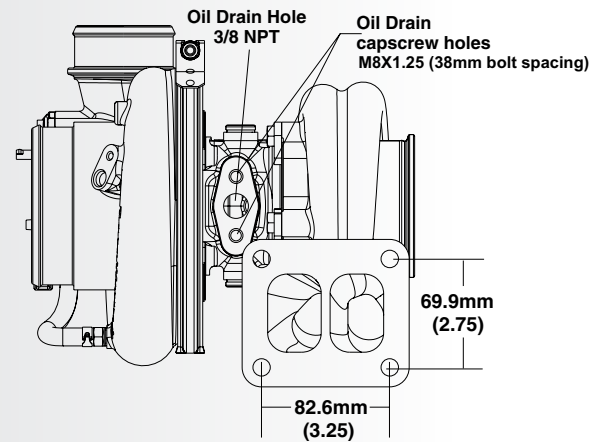
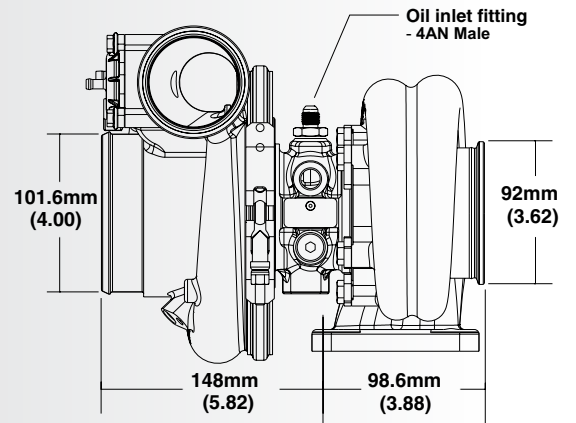
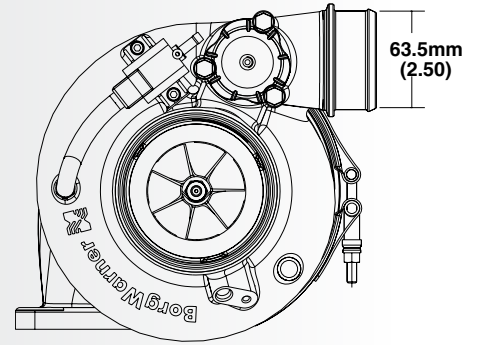

SUPER CORE CONFIGURATION

The following parts are not included as part of the super-core assembly: turbine housing, assembly clamp plate hardware, wastegate parts.