

- Dual ball bearing, oil & water-cooled CHRA
- Internally wastegated turbine housing, complete with actuator
- Turbine housing is cast from high-nickel "Ni-Resist" material
- Turbine wheel is cast from "Inconel" material for extreme applications
- Similar to GT2554R (471171-3) except for slightly larger turbine wheel, different turbine housing and wheel materials

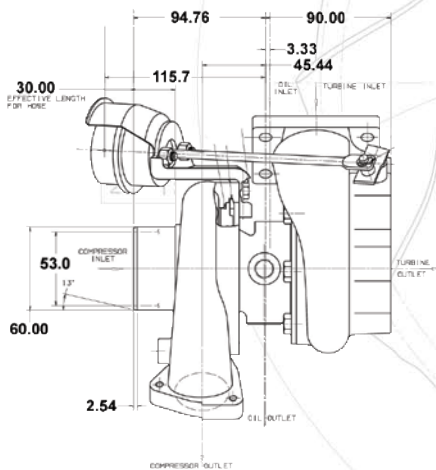

**DISPLACEMENT 1.4L - 2.2L**

**HORSEPOWER 170 - 270**

2000
1900
1800
1700
1600
1500
1400
1300
1200
1100
1000
900
800
700
600
500
400
300
200
100
0

GT2854R		COMPRESSOR				TURBINE		
Turbo PN	CHRA PN	Ind Whl Dia	Exd Whl Dia	Trim	A/R	Whl Dia	Trim	A/R
471171-9	446179-47	42.1mm	54.3mm	60	0.80	53.9mm	62	0.64

